

www.csiro.au

Australian Focus and Developments in Energy Technologies and Government Support of Low Emissions Energy Technologies

Dr David Brockway
Chief
CSIRO Energy Technology, Newcastle, AUSTRALIA

STAG meeting - Taiwan
19 November 2007



CSIRO

- Australia's national research organisation
- Australia's largest research organisation
- Established in 1926
- 19 Division; 9 National Research Flagships
- Budget approx US\$1,000m p.a.
 - 70 % Australian Government
 - 30% Other sources
- 6,500 staff located at 60 sites
- 60% of staff hold university degrees
 - >1800 doctorates
 - > 430 masters' degrees



Energy & Society

**Clean
Energy**

**Energy
Security**

**Australia
& Asia**

**Wealth
Creation**

Australian Energy Overview

Production

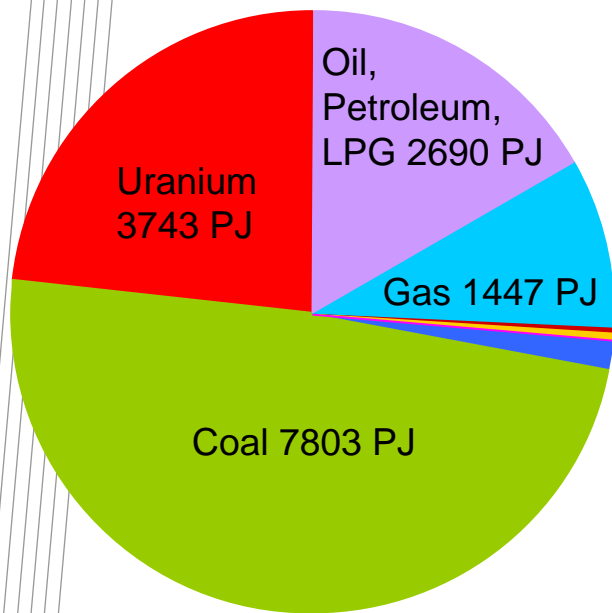

Electricity Generation

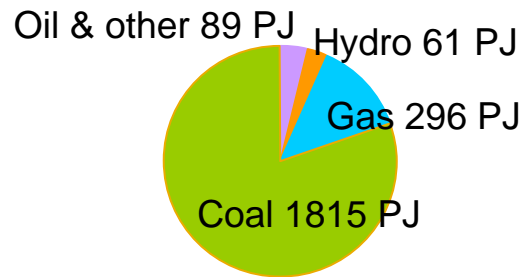

Hydro 59.4 PJ
Solar 4.0 PJ
Wind 1.4 PJ
Other 240 PJ

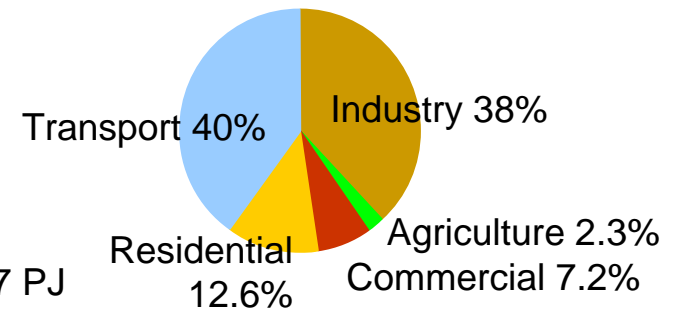

End Use

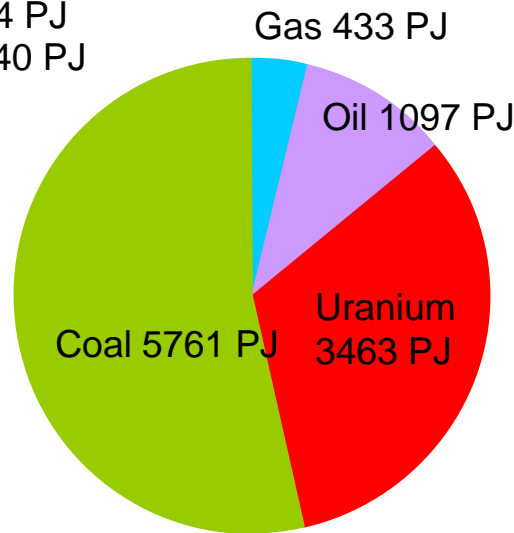

Exports

Source: ESAA



Energy Research Directions

A portfolio of technology options to address energy security, environmental emission, particularly GHG emissions and wealth creation from energy resources

- Major emphasis on new technologies for fossil fuels
- Focus on renewables
- Energy efficiency and demand management
- Liquid fuel security
- Uranium under review

Portfolio Of Technologies To Deliver GHG Reduction

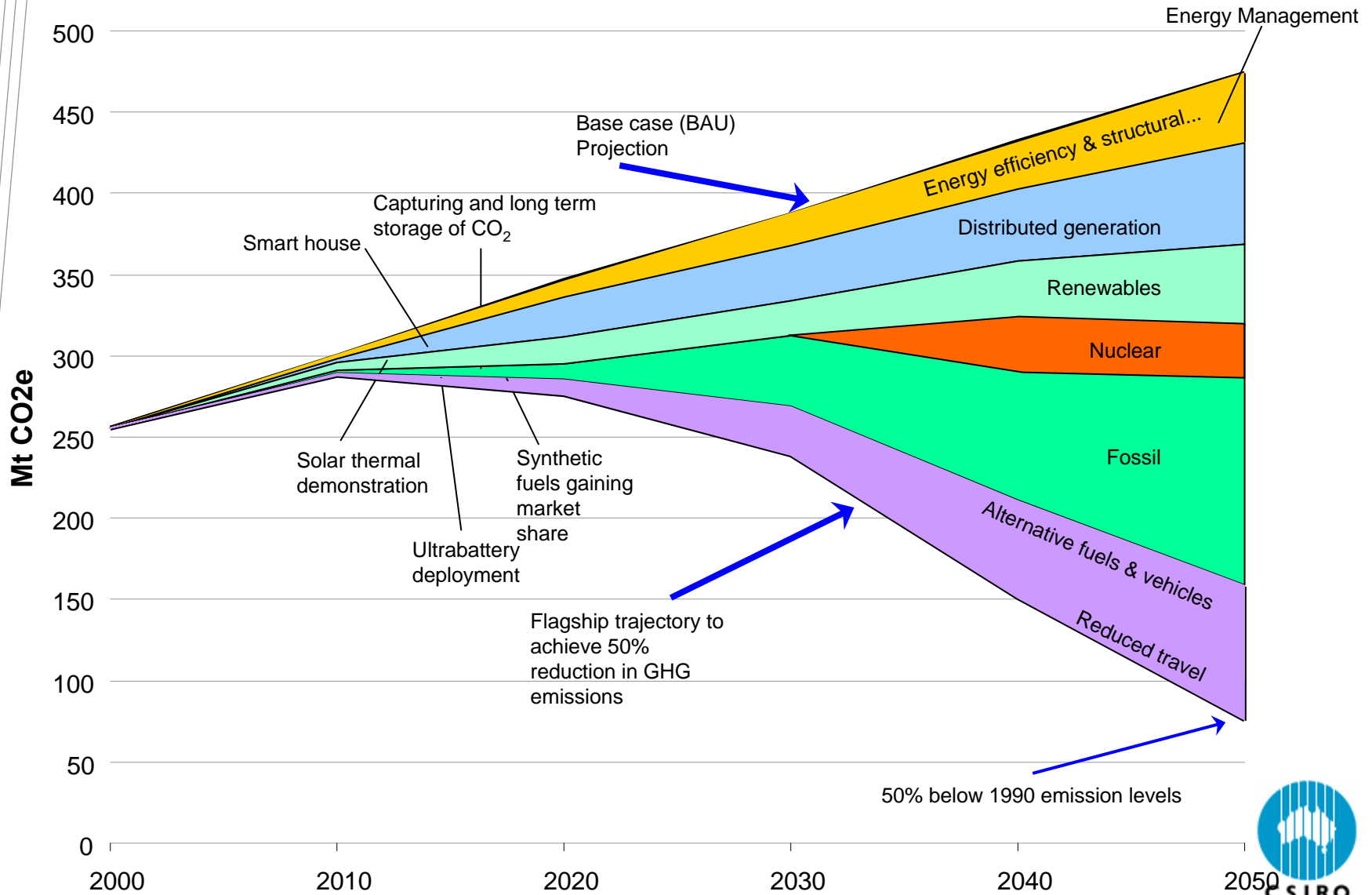

Technology and Thermal Efficiency

Tonnes CO₂ per MWh (Electrical)

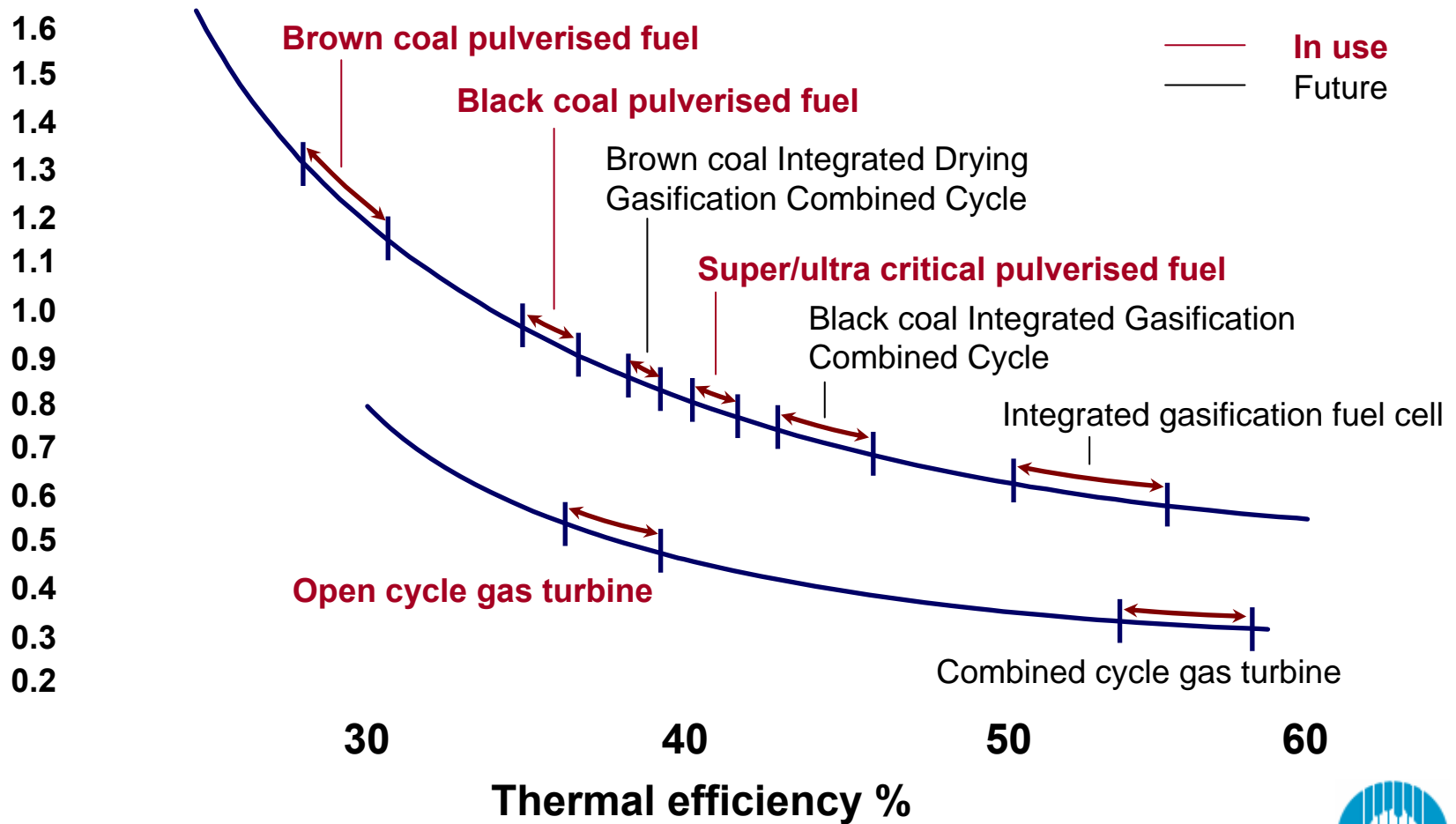

Near Zero Emissions

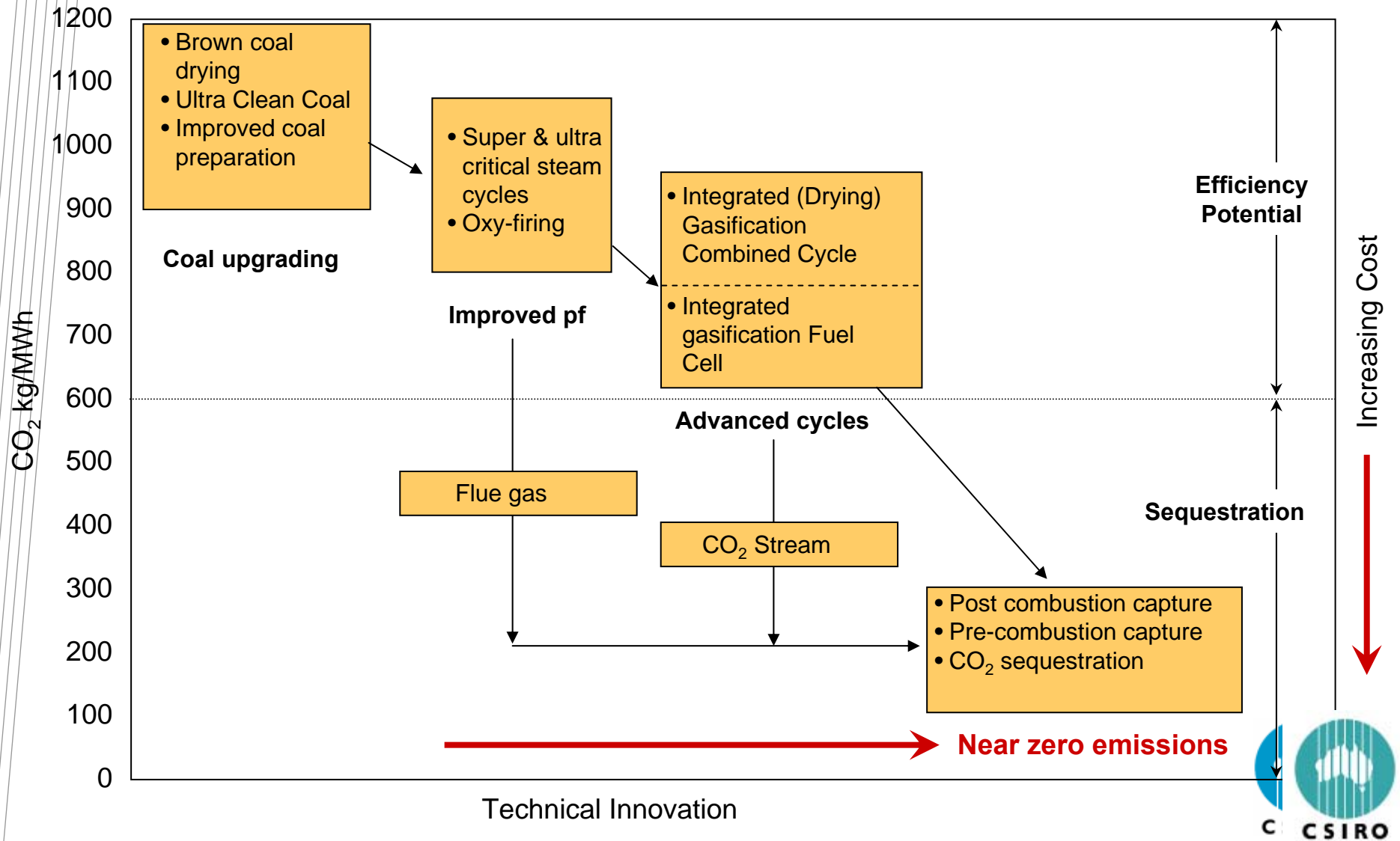

Capturing the CO₂

Three basic technology shifts

- Take out the CO₂ from the flue gases
 - pf-post combustion capture (PCC)
 - Oxy-pf
(possibility of retrofitting existing plant?)
- Take out the CO₂ prior to combustion/power generation
 - Integrated Gasification Combined Cycle with carbon capture (IGCC-CC) (requires new plant)

Coal Power Plant with Post Combustion Capture Technology

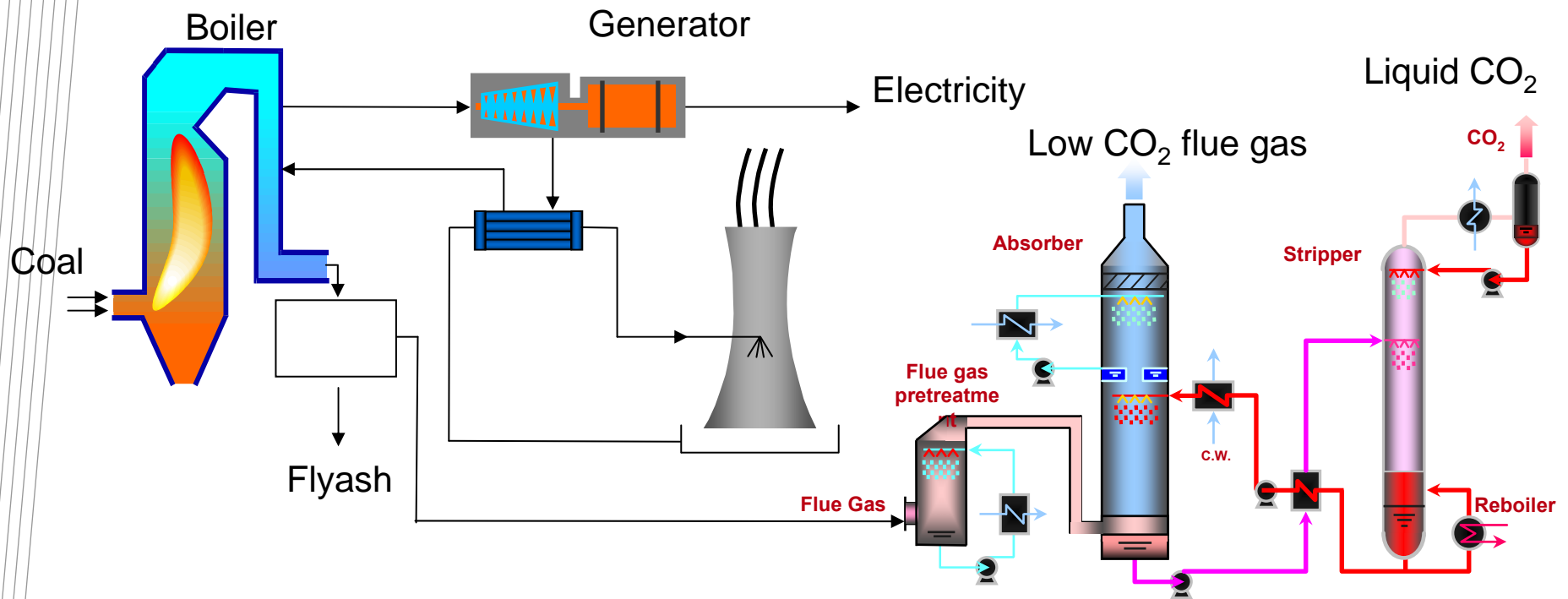

Thermal efficiency 28 - 33%
CO₂ emissions <100 kg/MWh

Oxy-pf with Flue Gas Liquefaction

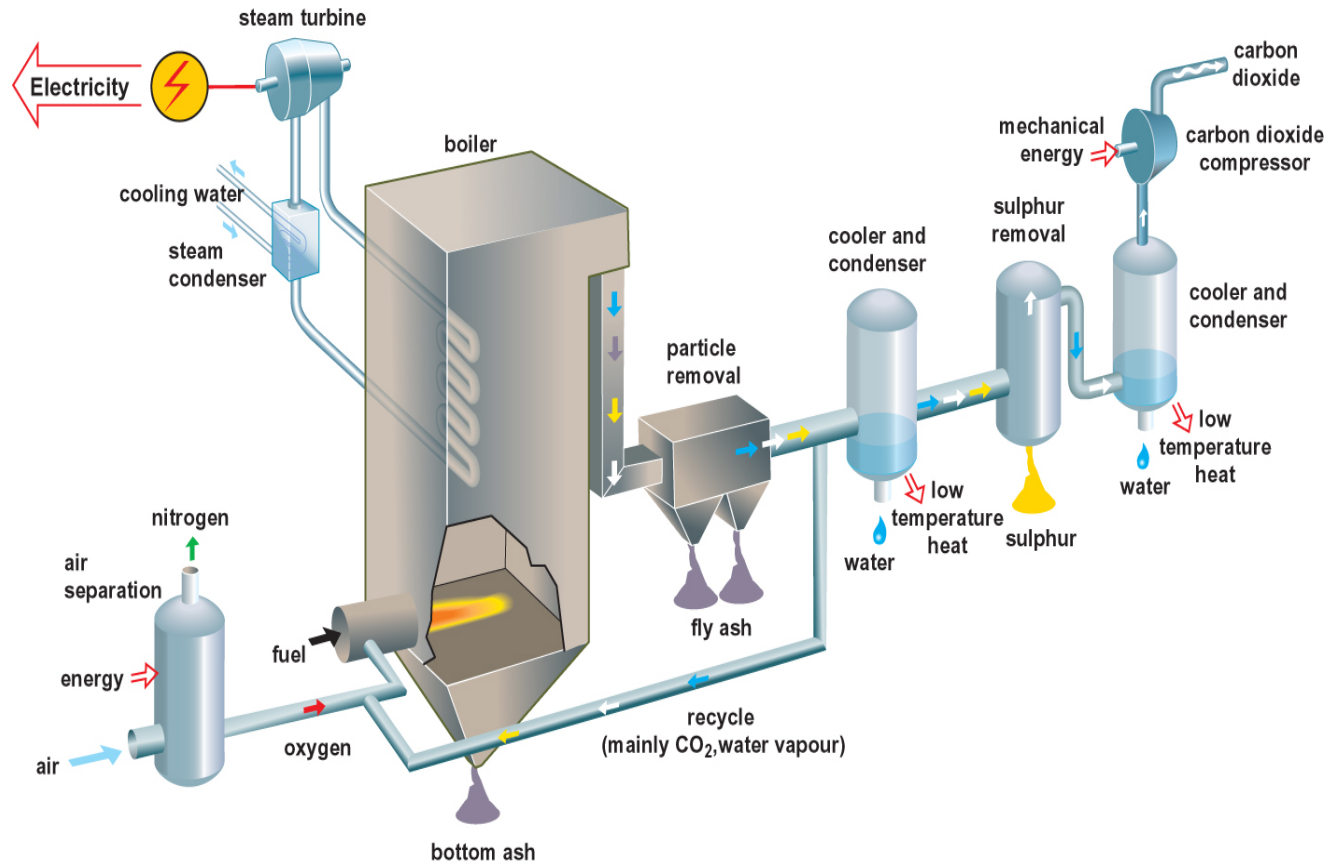

Thermal efficiency 28 - 33%
CO₂ emissions <100 kg/MWh

IGCC with Capture

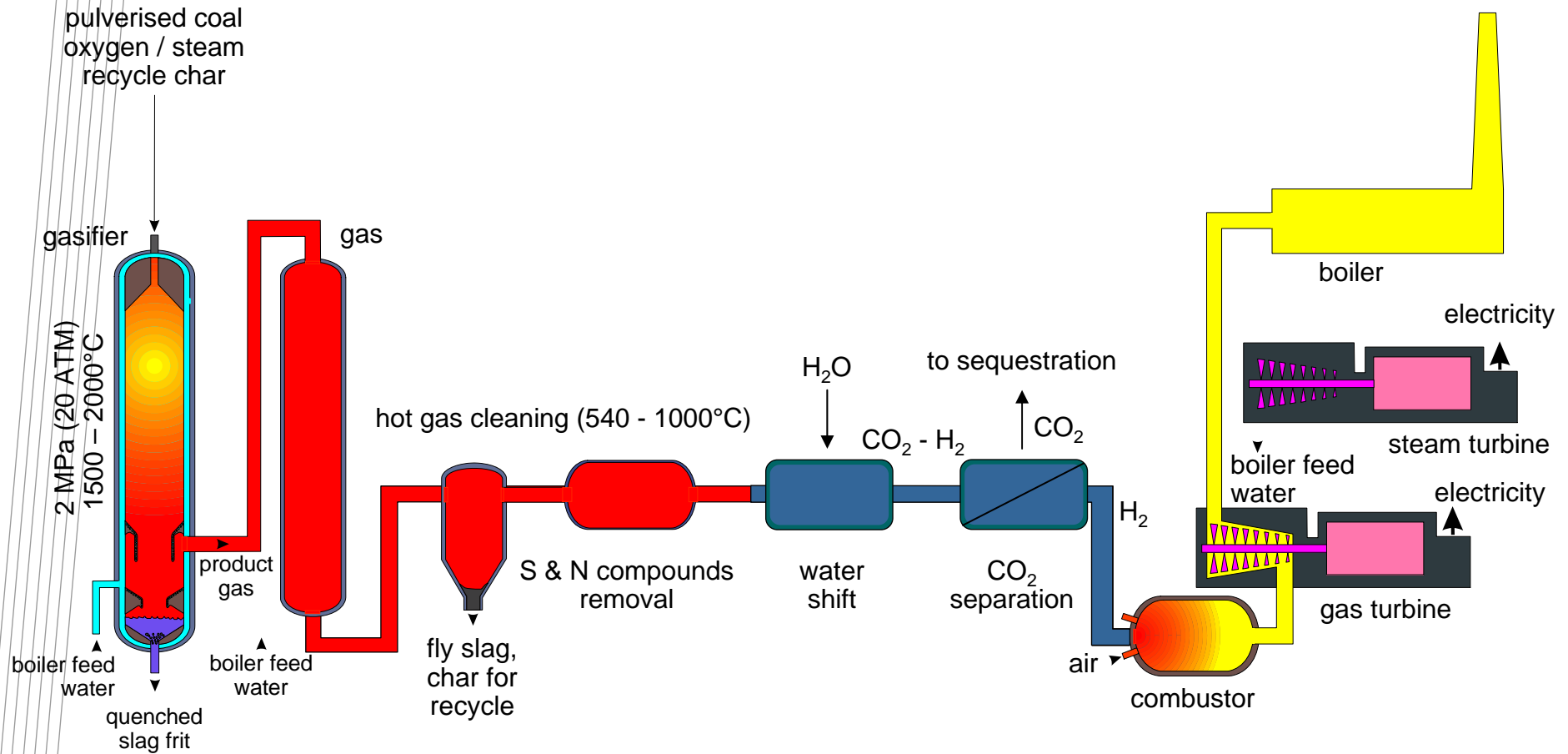

Thermal efficiency 36 - 41%
CO₂ emissions <100 kg/MWh

CO₂ Geosequestration Options

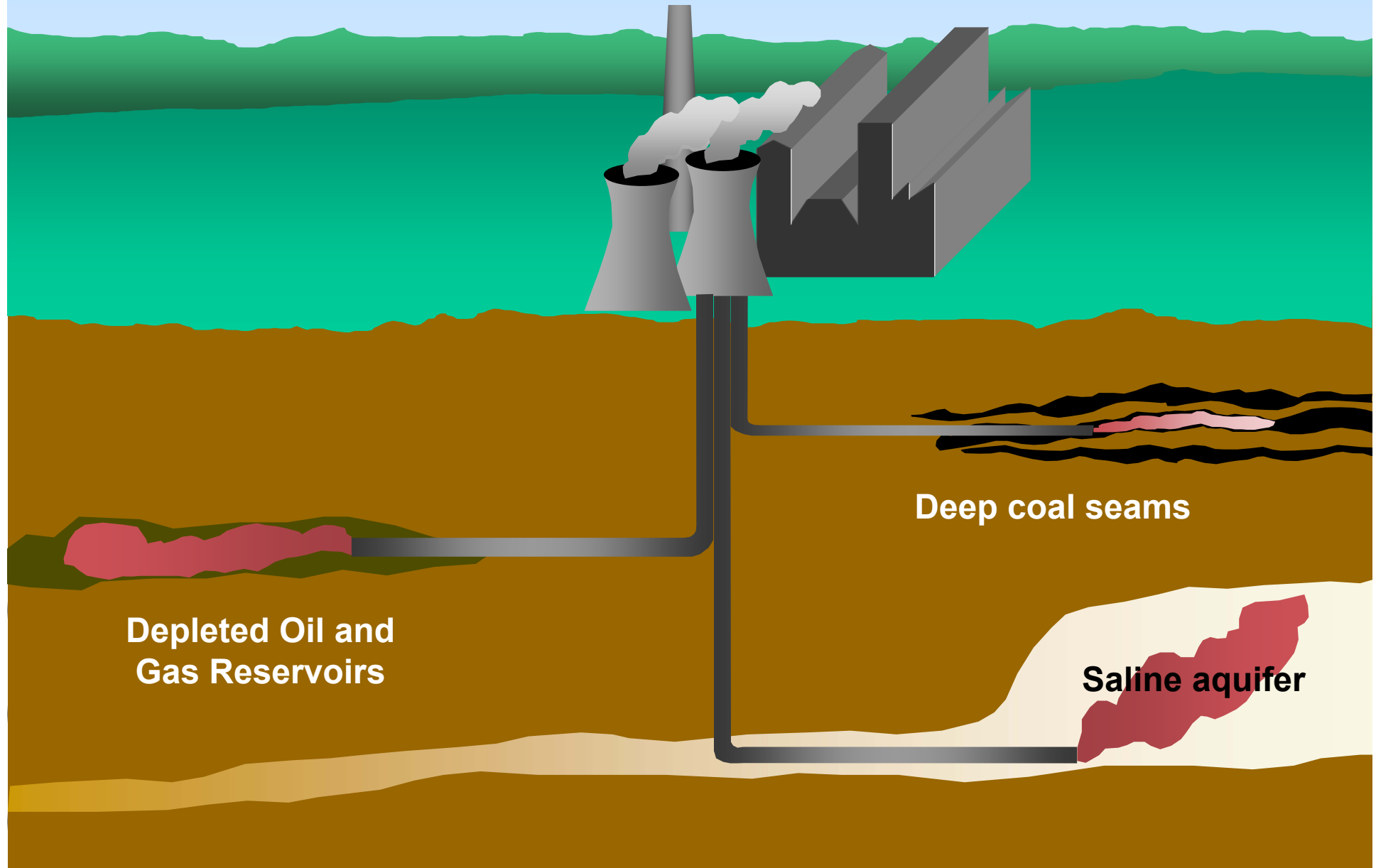

Future Coal-Fired Power Generation Technologies

The three current best practice technologies:

- pf boiler with PCC and Sequestration
- IGCC with CCS
- Oxy-firing pf boiler with Sequestration

are critically important for the intermediate term

But are these **NOT SUFFICIENT** to secure the long-term future of coal-fired power generation

Can only achieve efficiencies (HHV) of about 35 to 40%. Still an enormous and growing amount of CO₂ to Sequester.

Require coal-fired power generation with efficiencies much higher: >65%. Is this possible?

Fuel cycle efficiency for delivered electricity - 2030

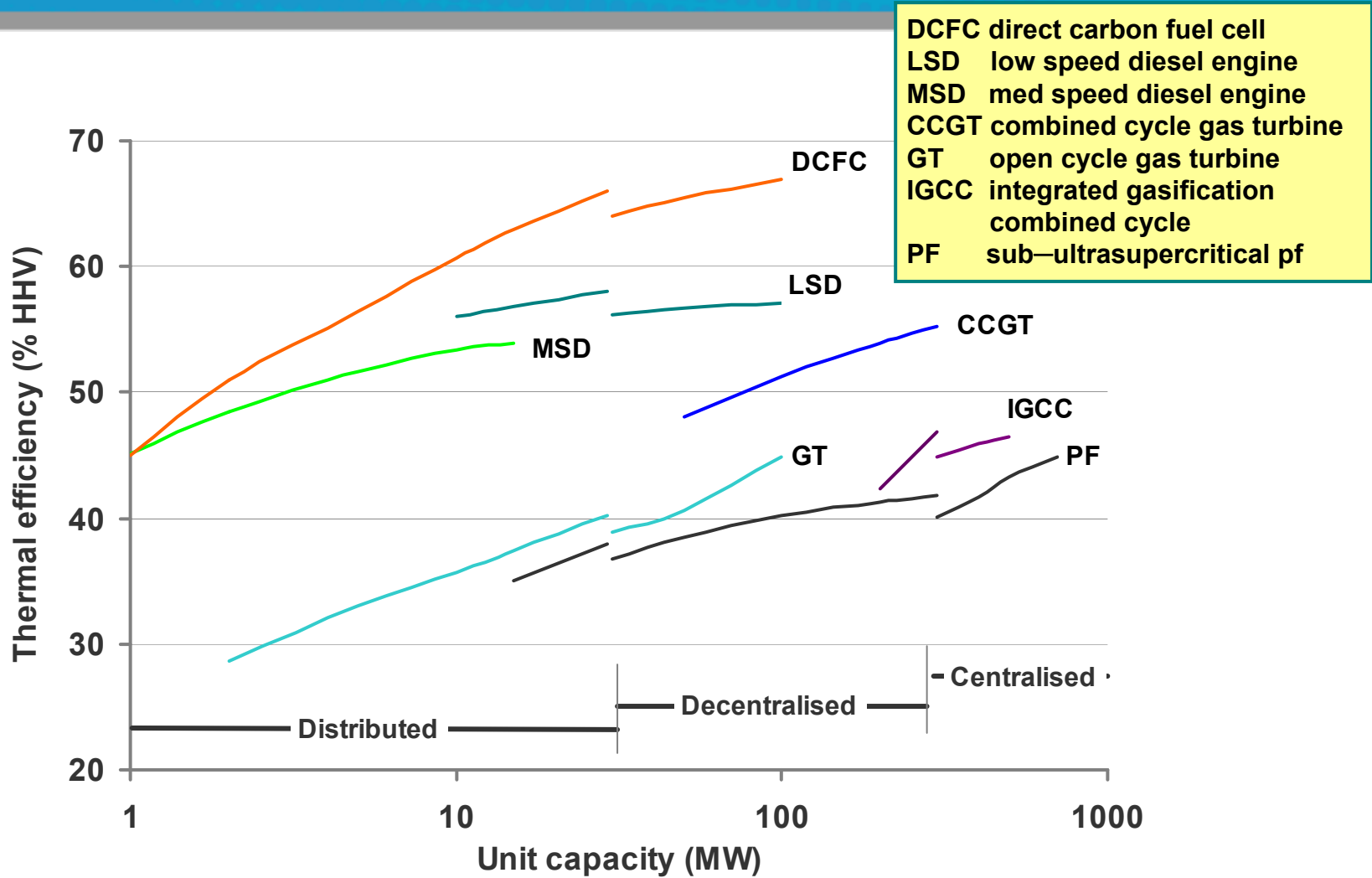

DCFC direct carbon fuel cell
 LSD low speed diesel engine
 MSD med speed diesel engine
 CCGT combined cycle gas turbine
 GT open cycle gas turbine
 IGCC integrated gasification combined cycle
 PF sub-ultrasupercritical pf



One possible combination for a 65% reduction

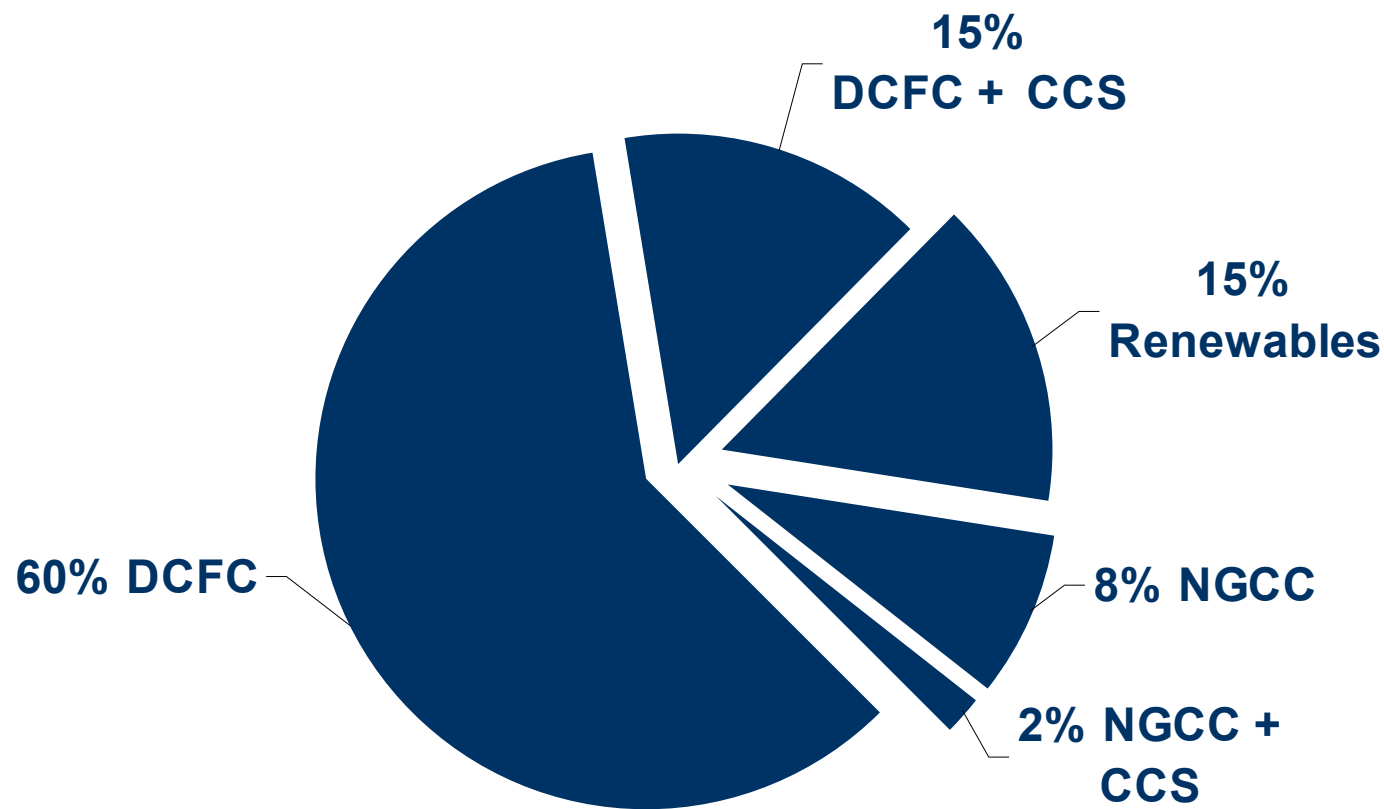

- Only 20% CCS is required

Solar Energy in Australia

- Solar energy is the world's largest sustainable energy resource
- Australia has the highest average solar irradiation of any continent
- Most of Australia's solar energy is where Australian's are not
- Theoretically, land area 50km x 50km supplies all Australia's electricity in 2020 (but requires storage and has high cost at present)

- 3 main paths from solar to useable energy:
 - Thermal
 - Thermo-chemical
 - Photon-based systems

- Solar Thermal is at an early stage of development and commercial adoption



Next Generation PVs: Organic Solar Cells

- Si remain high cost?
- OPVs Cheap
 - Cheap materials
 - Low temperature manufacturing from liquids
 - Low embodied energy
 - Compatible with more substrates
 - Fast = cheap!



Now



Soon ?

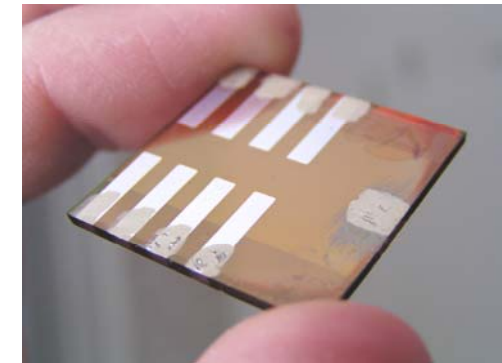

Power Plastic®

Energy Storage for Intermittency of Wind and Solar

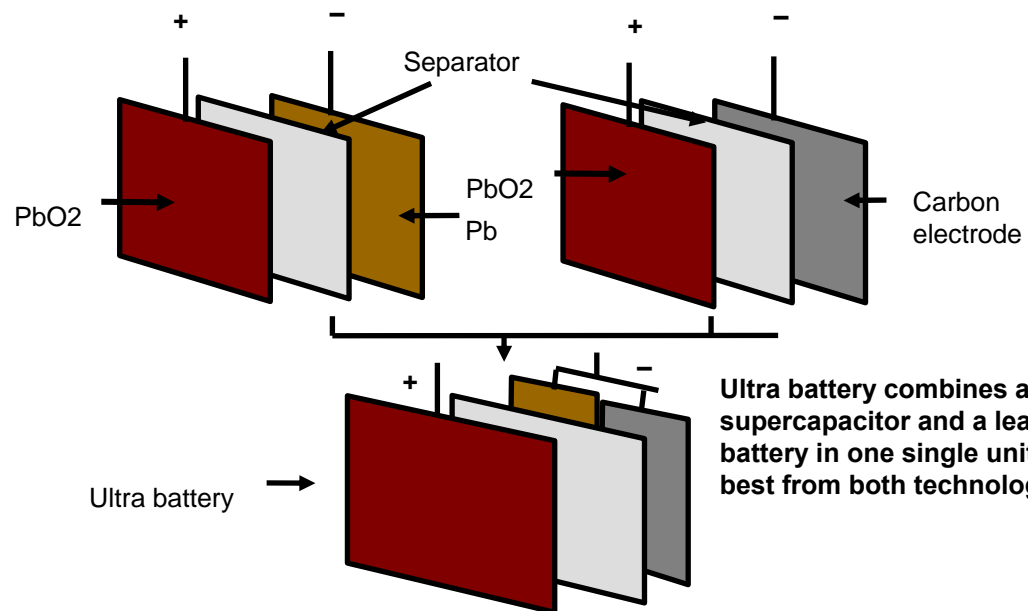
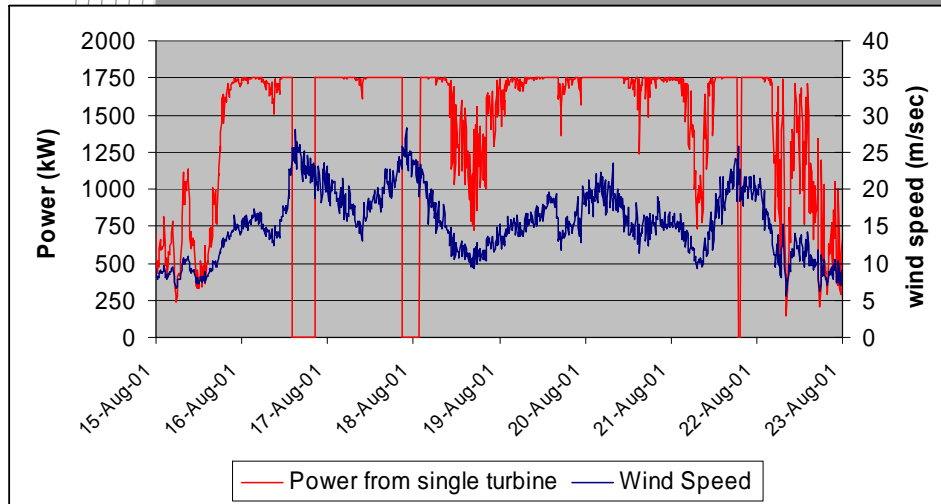

Distributed Generation and Energy Management

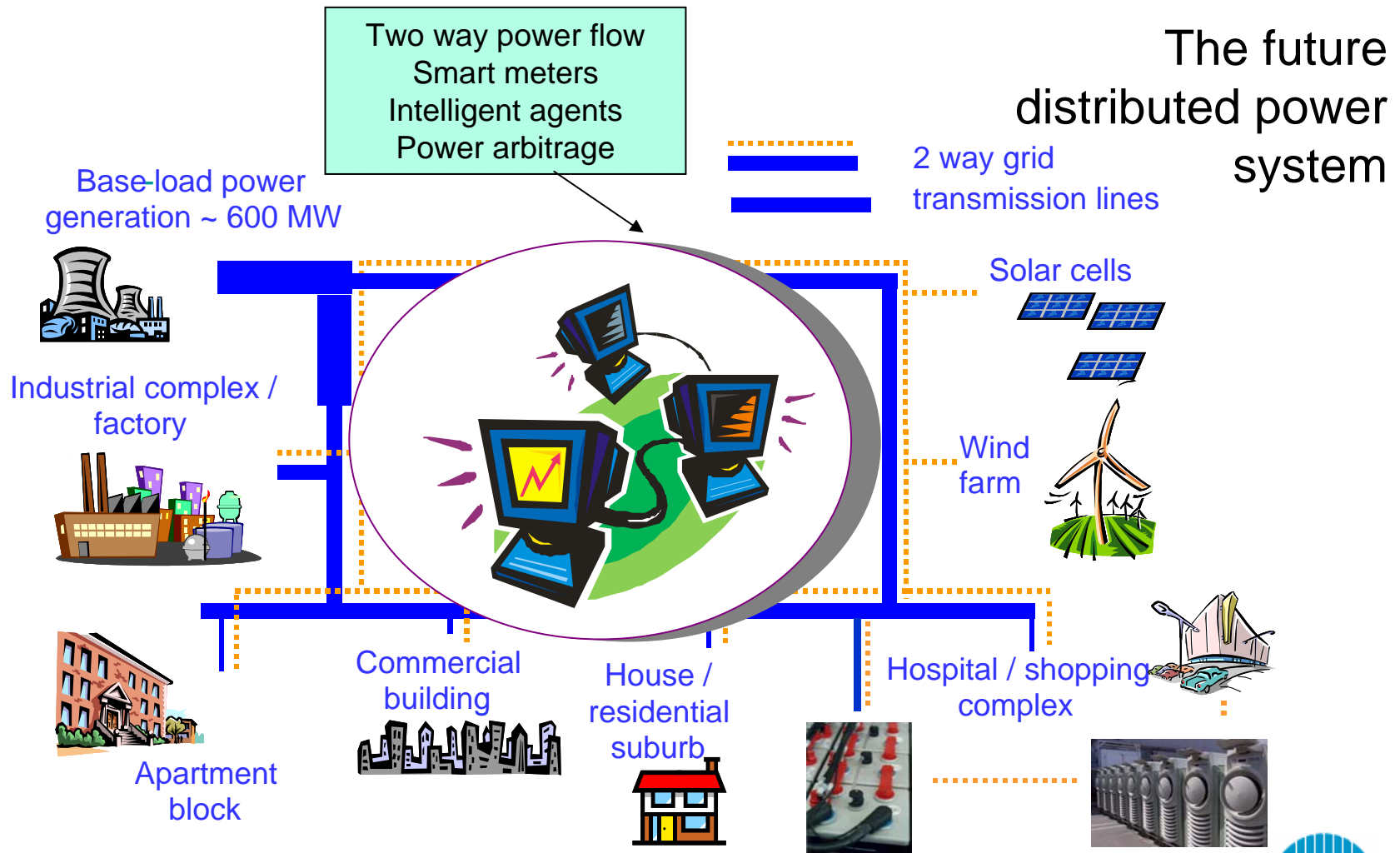

Liquid Fuel Security

Coal to Liquids:

- coal gasification
- direct coal liquefaction

Gas to Liquids:

- natural gas conversion
- solar gas to liquids

High Density Gas Storage:

- low pressure storage in nano-structured materials
- increasing energy density of gaseous fuels

Biofuels

Conversion processes must be low-emissions

Energy Storage for Hybrid-electric Vehicles



Lead-acid

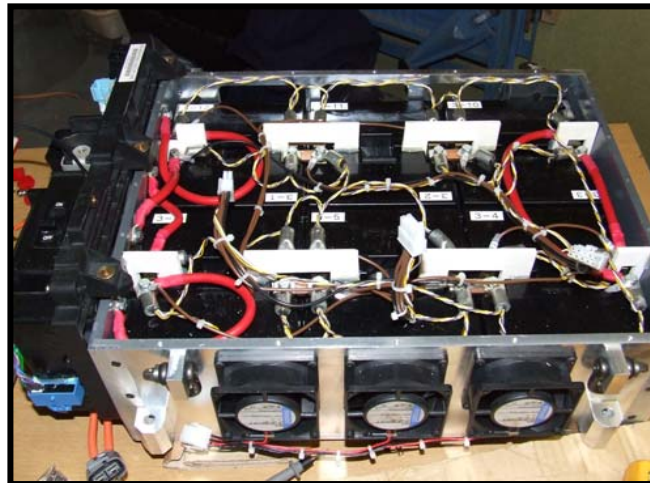

Ultrabattery

**Hybrid-electric
vehicle**





www.csiro.au

Australian Government Support for Low Emission Technologies



June 2004 Energy White Paper



- Outlines the Government's broader policy for *prosperity, security and sustainability* of energy supply
- Includes new initiatives supporting renewable energy and low emissions technologies

www.pmc.gov.au/publications/energy_future



Energy White Paper Programmes

Focused on addressing barriers to commercial introduction:

- \$75 million for Solar Cities
- \$14 million for wind forecasting
- \$20 million for energy storage
- \$100 million for R&D and commercialisation (Renewable Energy Development Initiative)
- \$500 million for Low Emissions Technology Development Fund

Other Complementary Programmes

- Green Vouchers for Schools
 - A\$336M over 5 years for solar hot water and rainwater tanks
- Solar Hot Water Rebates
 - A\$252M over 5 years for solar and heat pump hot water services
- Photovoltaic Rebate Program
 - A\$202M proportional rebate for cost of renewables on domestic and commercial buildings
- Renewable Remote Power Generation Programme (RRPGP)
 - \$328 million for up to 50% of the cost of RE generation equipment that reduces reliance on diesel fuel in remote, off-grid areas of Australia.
- Renewable Energy Commercialisation Programme
- Renewable Energy Industry Development (LETA)
- Renewable Energy Equity Fund

Australian Emissions Trading Scheme (AETS)

- Based on *Report of the Task Group on Emissions Trading*

www.pmc.gov.au/publications/emissions/

- Design and implementation to begin immediately – operational no later than 2012

- Led by Dept of Prime Minister & Cabinet

- Also see *Australia's Climate Change Policy*

www.pmc.gov.au/publications/climate_policy/

National Clean Energy Target (CET)

- Will complement the Australian Emissions Trading Scheme
- Designed to unify existing and proposed Commonwealth, States and Territory schemes into one national scheme
- Expanded range of clean energy technology support schemes and building upon Mandated Renewable Energy Targets (MRET)
- Additional 30,000 GWh pa by 2020 in addition to existing renewables of baseline of 16,000 GWh
- Covers renewables and low emissions technologies that emit $<200\text{Kg CO}_2/\text{MWh}$

National Election 24 November 2007

Alternative Government's Policies

- Sign Kyoto Protocol
- Introduce a National Emissions Trading Scheme
- \$500 million **Clean Coal Fund** to fund the deployment of clean coal technologies
- \$500 million **Renewable Energy Fund** to develop, commercialise and deploy renewable energy in Australia.
- \$240 million **Clean Business Fund** to help business and industry deliver energy and water efficiency projects, with a focus on productivity and innovation.
- \$150 million **Energy Innovation Fund** to keep Australia's world leading scientists and researchers in Australia, rather than losing them overseas.

National Election 24 November 2007

Alternative Government's Policies (continued)

- Set a 20 per cent Renewable Energy Target by 2020;
- \$8000 rebates for solar power, \$1000 rebates for solar hot water systems, \$500 rebates for grey water piping and rainwater tanks, \$500 rebates for landlords to install insulation and \$10,000 in low interest Green loans for solar systems and water and energy savings measures.
- Invest \$15 million in a Clean Energy Export Strategy;
- Invest \$20 million in a Clean Energy Innovation Centre; And
- Invest in a Green Car Innovation Fund to develop and build green cars in Australia.

CSIRO Energy Technology

Dr David Brockway
Chief

Phone: +61-2-4960-6046

Email: david.brockway@csiro.au

Web: www.csiro.au

www.csiro.au

Thank you

Contact Us

Phone: 1300 363 400 or +61 3 9545 2176
Email: enquiries@csiro.au Web: www.csiro.au

